

Testpassport**Q&A**



H i g h e r Q u a l i t y

B e t t e r S e r v i c e !

We offer free update service for one year
[Http://www.testpassport.com](http://www.testpassport.com)

Exam : **000-240**

Title : IBM Sterling Configurator
V9.1, Deployment

Version : Demo

1.A car manufacturer wants to display a list of available cars based on what the customer chooses for the:

- brand of the car (e.g. Honda, Ford, Toyota), and
- type of the car (e.g. hatchback, Sports Utility Vehicle (SUV), convertible).

Additional information:

- "CarType" is declared as List type.
- "AvailableCars" is declared as String.
- The rule fires on success.

What should be the rule fragment/condition written for this?

- A. value(AvailableCars) not in list(CarType) [Fragment is false]
- B. value(AvailableCars) not in propval(CarType) [Fragment is false]
- C. propval(AvailableCars) not in list(CarType) [Fragment is false]
- D. propval(AvailableCars) not in parent(CarType) [Fragment is false]

Answer: C

2.A modeler is working on a rule to determine if the customer's location is one of the 10 possible locations where a discounted offer can be given. What type of property SHOULD be used for storing all 10 of the locations in one property.?

- A. List property
- B. String property
- C. Location property
- D. String Array property

Answer: A

3.A company wants to give its customers a 10% volume discount for its Professional Services if the order totals 100 or more hours. The \$250 hourly (undiscounted) base rate for Professional Services is retained in an Option Item under an Option Class called base rates in the model and is never displayed in the UI. Rules will be used to set the UI: PRICE for the Professional Services Option Item displayed in the UI based on the quantity of hours ordered and the UI: PRICE of the hidden base rate Option Item. Review the following images which show what is presented to the user in the UI with and without a discount.

No Discount:

Services		
Name	Hourly Rate	Quantity
Professional Services	250.0	0

10% Discount

Services		
Name	Hourly Rate	Quantity
Professional Services	225.0	100

When creating these assignment rules, which function needs to be used to retrieve the hourly base rate for Professional Services?

- A. sum
- B. value
- C. lookup
- D. propval

Answer: D

4.A modeler has to create a rule with many fragments. In which order should the fragments be set up for better performance?

- A. The nested fragments should come first.
- B. The least probable fragment should come first.
- C. The sequence of the fragments do not make any difference.
- D. The fragments that use custom function handlers should come first.

Answer: B

5.A modeler creates a Model for a desktop with multiple layers of Option Classes. To keep the price of the desktop low, the modeler decided on a maximum price for each group of components and marked it at the appropriate Option Class level with the property "maxPrice". The rules for validating that the price does not go beyond the max set for that component or subcomponent is defined at Model and attached at the Option Items. What function can be used in the rule to determine the "maxPrice" for each component?

- A. max()
- B. value()
- C. parent()
- D. propval()

Answer: C

6.A furniture company has a Model for a house with an option to select different types of furniture commonly found in a house (e.g. tables, chairs etc). Each of those furniture types are modeled as Option Classes and the available options are defined as Option Items. The prices are defined as a property on Option Items. Multiple selections can be made in each of the furniture types and quantities can be entered for them. Which function(s) will be needed in a rule attached at the Option Class level to determine the average price of each of the furniture type selected?

- A. sum()
- B. childSum()
- C. sum(), count()
- D. childSum(), count()

Answer: B

7.A Model is developed per the following image:

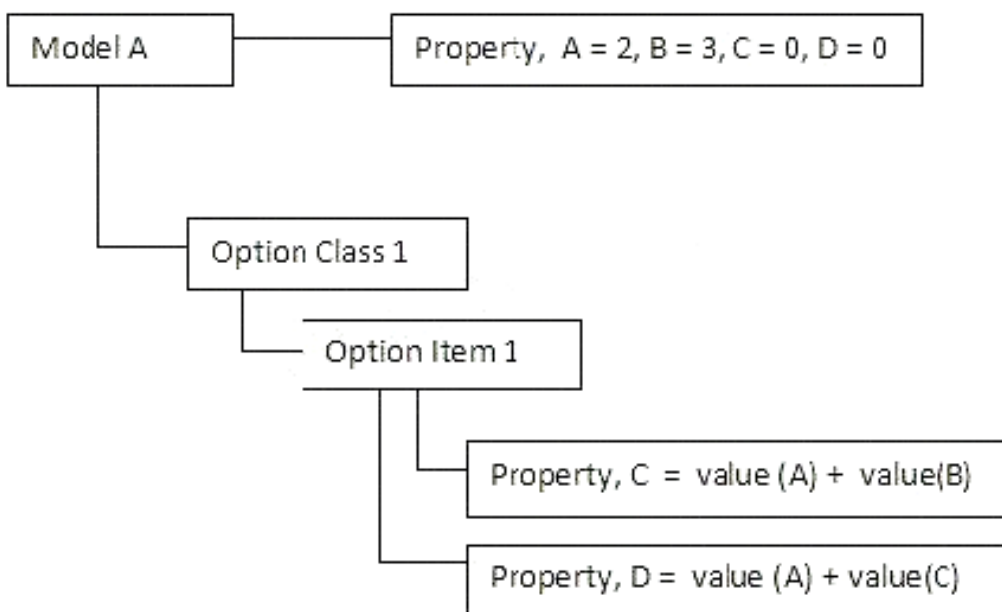

To ensure consistency and control of priorities, which of the following statements is TRUE?

- A. "Property, D" will always be equal to 5.
- B. The formula cannot be attached to property as depicted in the image.
- C. To ensure that the value of "Property, D" is 7 after Model execution, change the priority of formula firing so that the formula for deriving "Property, C" is fired before the formula for "Property, D".
- D. To ensure that the value of "Property, C" is calculated before the value of "Property, D", replace the formula with two rules. Rule1 calculates "Property, C" and Rule2 calculates "Property, D". Set the priority for Rule1 is set to 40, and the priority of Rule2 to 50.

Answer: D

8.Review the following Model:

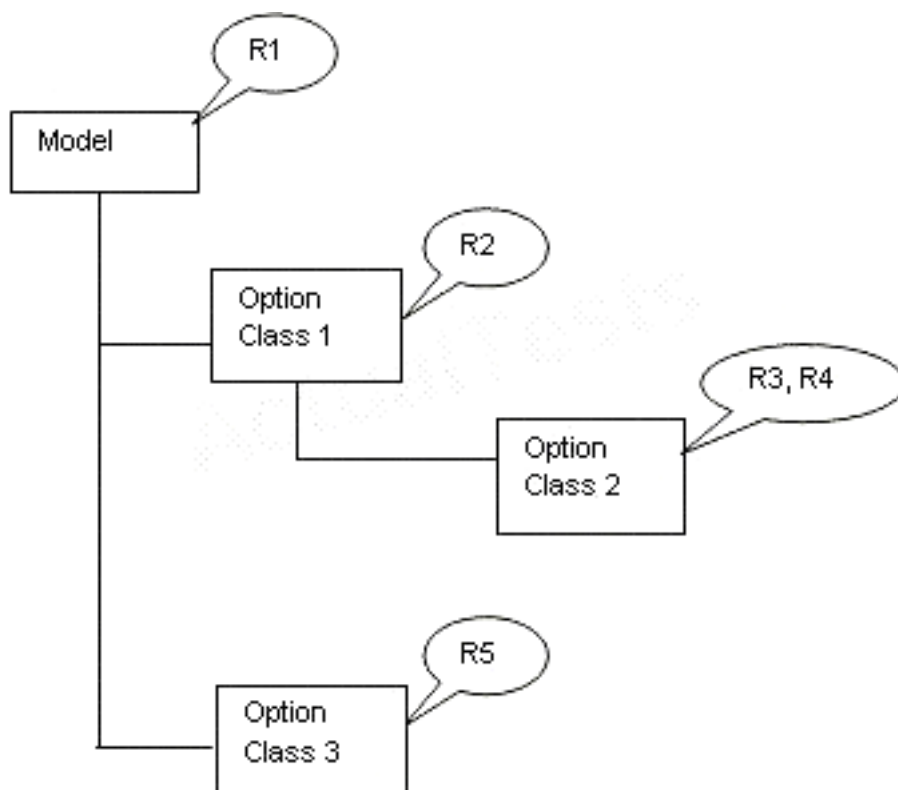

The callouts (i.e. "R1", "R2", "R3, R4" and "R5") denote the rules assigned at the different levels. For the rules assigned to the same node, assume that the rules are listed in the increasing order of priority value. What is the sequence in which the rules will be evaluated?

- A. R1, R2, R3, R4, R5
- B. R1, R2, R4, R3, R5
- C. R1, R2, R5, R4, R3
- D. R3, R4, R2, R5, R1

Answer: D

9.A modeler needs to create a property to represent the quantity of televisions in a home where the value needs to be used in a calculation. What type of property should be created?

- A. List property
- B. String property
- C. Integer property
- D. Number property

Answer: D

10.When naming properties, a modeler avoids using names that start with an "_" (underscore). The modeler is correct to do this, because names that start with an "_" (underscore) are which type of properties?

- A. UI Properties
- B. UEV Properties
- C. System Properties
- D. Rule Trace Properties

Answer: C

11.A major bike manufacturer sells customizable bikes online, and includes assembly and shipping. For a bike to be completed, the user must select a frame, tires and gear systems. There are several choices available for the user in each category, but there are some compatibility issues between certain types of frames and the third-party gear systems that the manufacturer uses. For example, there are three sizes the bike frames: 19" 20" and 22". There are three models of gear systems that the manufacturer offers: 6-speed, 18-speed and 24-speed. While 6-speed and 18speed fits all the frame sizes, 24-speed is a premium exclusive model and fits only the 22". The requirement calls for compatibility to be pointed out to the user. What is the correct way to model this product?

- A. Use a rule to automatically fix compatibility issues.
- B. Use a Constraint Table to manage the allowable configurations.
- C. Use a list to list down the different options available for each frame.
- D. Define different properties for gear system 24-speed to distinguish it from 6-speed and 18speed.

Answer: B

12.A modeler wants to give a discount on the price of cars, but only if the following conditions are satisfied:

- The seats are bucket seats in either green or yellow.
- The price of the car is more than \$20,000.
- The time of the purchase is either afternoon or evening.

The modeler creates a rule for this and it is set to trigger on success. How will this rule condition be defined in the Visual Modeler?

A.

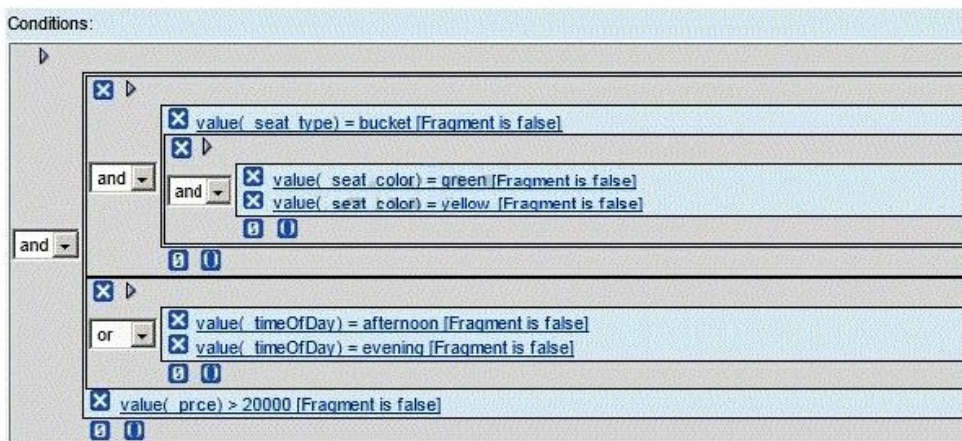

B

Conditions:

- value(seat type) = bucket [Fragment is false]
- or
 - and
 - value(seat color) = green [Fragment is false]
 - value(seat color) = yellow [Fragment is false]
- and
 - value(timeOfDay) = afternoon [Fragment is false]
 - value(timeOfDay) = evening [Fragment is false]
- value(price) > 20000 [Fragment is false]

C.

Conditions:

- value(seat type) = bucket [Fragment is false]
- and
 - or
 - value(seat color) = green [Fragment is false]
 - value(seat color) = yellow [Fragment is false]
- or
 - value(timeOfDay) = afternoon [Fragment is false]
 - value(timeOfDay) = evening [Fragment is false]
- value(price) > 20000 [Fragment is false]

D.

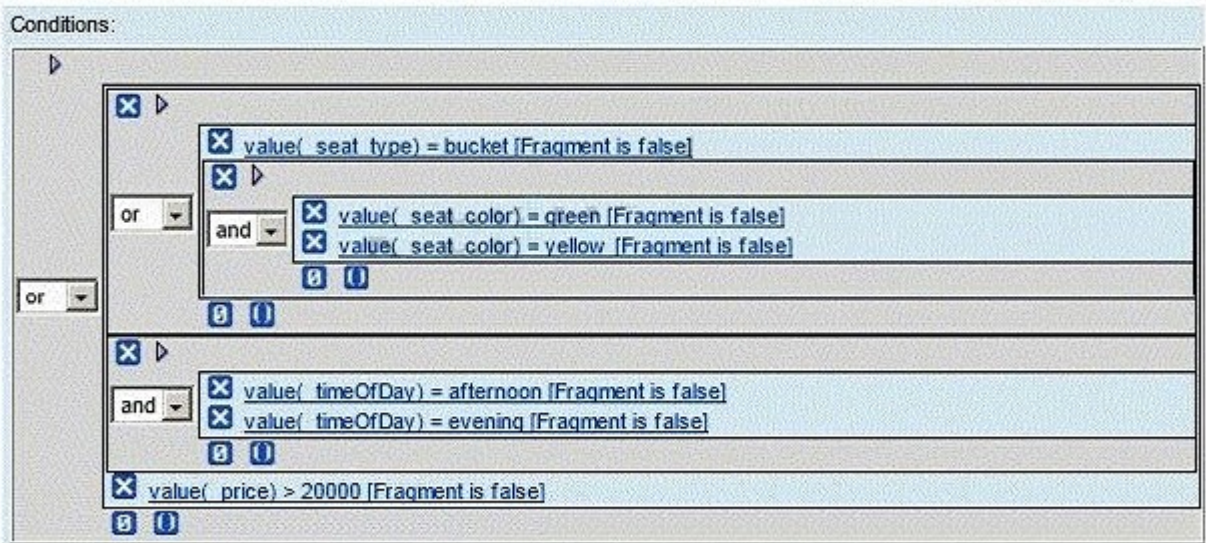

- A. Exhibit A
- B. Exhibit B
- C. Exhibit C
- D. Exhibit D

Answer: C

13.A Model has property values that change frequently, and these changes are communicated by an external vendor. The modeler needs to make these changes as required. What is the MOST efficient way of updating the Model with these frequent changes?

- A. Make the changes in the database table.
- B. Make the changes using the Visual Modeler.
- C. Export the current Model and make changes in the Model XML. Import the changed Model.
- D. Create a common Worksheet and maintain it externally in a Comma Separated Value (CSV) file. Upload it with the new property values.

Answer: D

14.To represent an entertainment collection, a modeler creates a Model Group with Models for books, songs, movies. etc. Option Classes in each Model represent different genres and the Option Items are the individual works of art (specific songs, movies, books, etc.). Given that the term "artists" is applicable to songs and movies but not to books, where should a property denoting "artists" be defined and attached?

- A. Property is defined at the Model Group and attached at the Models.
- B. Property is defined at the Models and attached at the Option Class.
- C. Property is defined at the Model Group and attached at the Option Items.
- D. Property is defined at the Option Class and attached at the Option Items.

Answer: C

15.A modeler is about to create an Option Class for logos for a Model of t-shirts. The modeler discovers that there is a Model for logos and that it has been used as a sub-model in a Model for bags. Instead of

attaching the Model for logos as a sub-model to the Option Class, the modeler wants to copy the reference for the sub-model from the Model for bags. What are the possible advantages of doing this?

- A. Any properties attached to the sub-model reference are copied over and may be useful.
- B. Any rules and properties attached to the sub-model reference are copied over and may be useful.
- C. There is no advantage. It is same as attaching the Model for logos as a sub-model to the Option Class.
- D. It is not possible to copy the sub-model reference.

Answer: B